



Aqua One®

Inspiring Excellence in Fish Care!

AquaNano 30/40



BEFORE YOU WORK ON YOUR AQUARIUM, WASH YOUR HANDS AND ARMS. IT IS VERY IMPORTANT TO REMOVE DIRT, MOISTURISER AND OTHER IMPURITIES.



UNPACK ALL FILTER MEDIA AND RINSE BEFORE INITIAL USE.

RINSE THE INSIDE OF THE AQUARIUM WITH WATER TO REMOVE ANY DUST OR OTHER CONTAMINANTS.

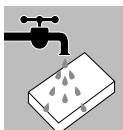

ALL FISHES HAVE SPECIFIC REQUIREMENTS FOR THEIR CARE.

PLEASE SEEK ADVICE FROM YOUR AQUA ONE RETAILER FOR CORRECT CARE REQUIREMENTS AND SPECIES COMPATIBILITY.

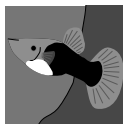

Read and follow all safety instructions and important notices in these instructions as well as on the product itself.



Like us on
Facebook

Download the Aqua One App.



Download on the
App Store



GET IT ON
Google Play



CUSTOMER CARE

Thank you for choosing this Aqua One product.

Your Aqua One product is covered for parts and labour for 1 year from the date of purchase as detailed in the terms of the Guarantee in this instruction manual. For any inquiries or concerns regarding this product or any of our products, please do not hesitate to contact your local Aqua One Retailer or visit Aqua One Customer Care online in your country of purchase via the websites listed.

Australia:
www.aquaone.com.au

New Zealand:

www.aquaone.co.nz

United Kingdom:

www.aquaone.co.uk

All other countries:

www.aquaone.com.au



IMPORTANT SAFEGUARDS



If you are in any doubt about the electrical installation or safety of this product you must consult a qualified electrician.



Water and electricity can be dangerous. Do not attempt repairs yourself. Return the appliance to an authorised service facility for repair.



Make sure any component mounted on a tank is securely installed before operating it.



Children should be supervised when using this item.

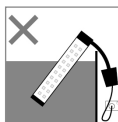

If the appliance or any electrical component of the appliance (non-immersible equipment only) falls into the water or gets wet, don't reach for it. Unplug it and then retrieve it.

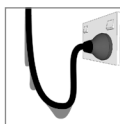

Arrange a drip loop for each cable to stop water entering the power socket. If the plug or the socket does get wet, disconnect the fuse or circuit breaker before unplugging the power plug.

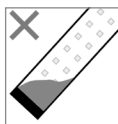

If the appliance shows any sign of water leakage, unplug it from the power source. Examine the appliance after installation. It should not be plugged in if there is water on parts which are not intended to be wet.

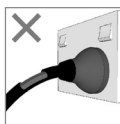

Don't operate the appliance if it has a damaged cord or plug, or if it is malfunctioning, or damaged in any manner.



Do not use the appliance for reasons other than the intended use.

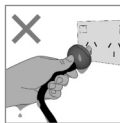

Ensure your hands are dry when turning the power switch on or off and when inserting or removing the power cable from the socket.

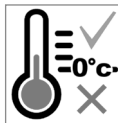

Do not install or store the appliance where it will be exposed to weather or temperatures below freezing.

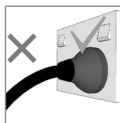

Never yank the cable to pull it from the socket. Pull the plug carefully to disconnect.

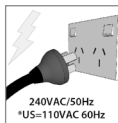

Ensure input voltage is the same voltage as your local power supply.

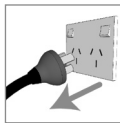

Unplug the appliance from the electrical outlet when not in use or before any type of maintenance or cleaning.



A G.F.C.I (Ground fault circuit interrupter) & surge protector is recommended for all electrical appliances.

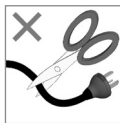









All products are supplied with fitted plugs. This plug should not be tampered with in any way or removed. Removal or tampering with the plug invalidates our guarantee offered with this product.







For Indoor use only.

SPECIFICATIONS

 MODEL	 AQUARIUM VOLUME	 DIMENSIONS	 FILTER FLOW RATE	 POWER CONSUMPTION
30	22 L	30L x 30D x 30H CM	400 L\HR	39 W
40	55 L	40L x 40D x 40H CM	500 L\HR	74.6 W

 FILTER	 HEATER	 LED LIGHTING
6 W	25 W	8 W
8 W	55 W	11.6 W

REPLACEMENT PARTS

 MODEL	 IMPELLER	 CARBON CARTRIDGE	 CERAMIC CARTRIDGE	 15 PPI SPONGE
30	1I	1C	102C	116S
40	26I	1C	102C	117S



Carefully unpack the aquarium making sure you keep all the packing material until all the parts of the product have been found and the product has been assembled.

This product is shipped to you in a factory sealed carton. Should the product malfunction in any way or if the unit is damaged and requires replacement, contact the retailer where the product was purchased for inspection.



WHAT'S IN THE BOX

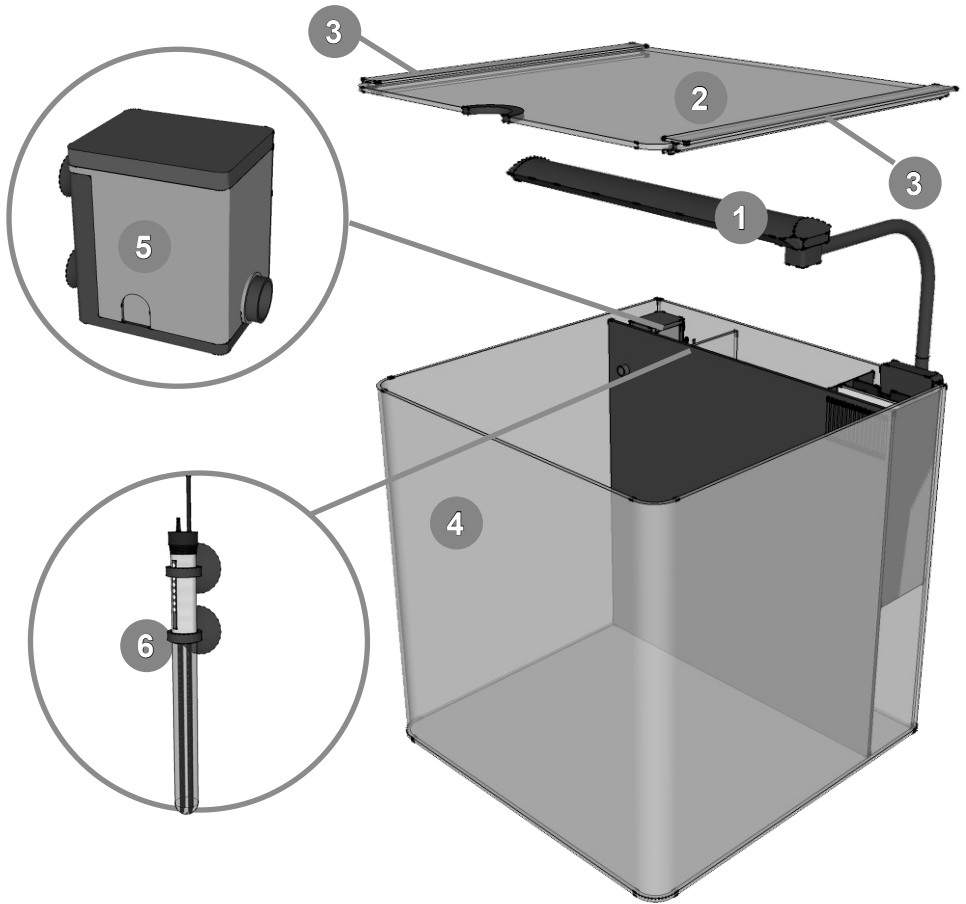

MAJOR COMPONENTS

1	LED Light Unit
2	Glass Lid
3	Lid Supports (x2)
4	Glass Tank Body
5	Filter
6	Heater

KNOW YOUR FILTER

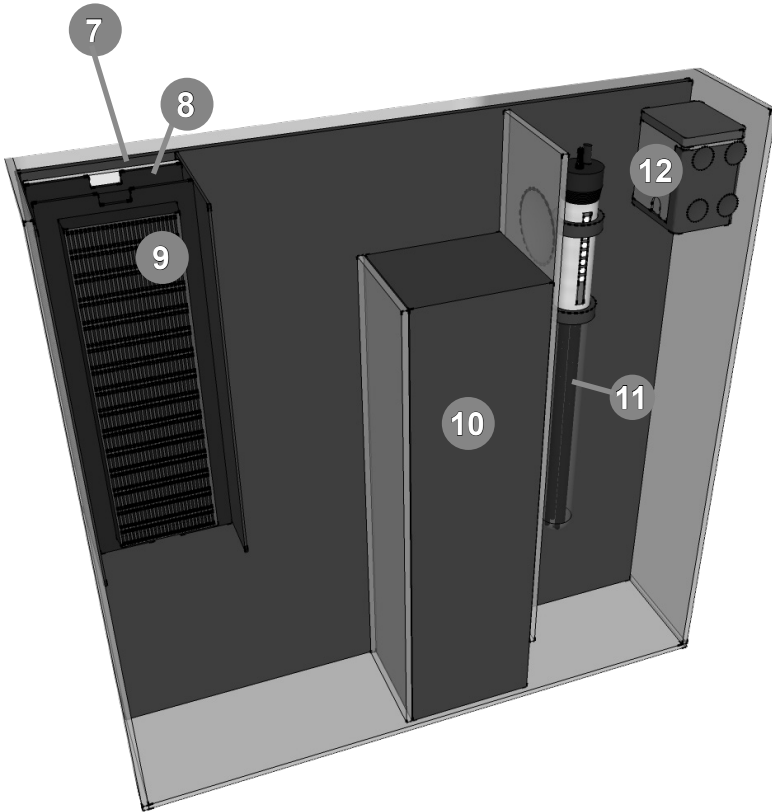

FILTER COMPONENTS

7	Intake
8	Carbon Cartridge
9	Ceramic Cartridge
10	Sponge
11	Heater
12	Pump



SETTING UP

 Consider where you are going to place the aquarium. Avoid direct sunlight and areas that experience large temperature fluctuations such as near heaters or air conditioners.

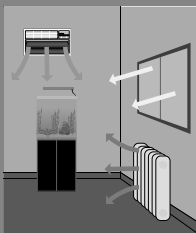

Place the aquarium stand on a level surface strong enough to support the weight of the aquarium, all equipment, substrate, ornaments and water in the aquarium. Note that water is heavy (1kg per litre).

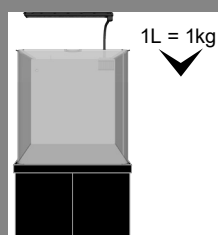

FILTER ASSEMBLY

Rinse the following with tap water.
DO NOT WASH IN SOAP OR DETERGENT.

This is the only time tap water should touch the filter media.

Black Filter Sponge, Carbon and Ceramic Cartridges, Inside Glass Tank

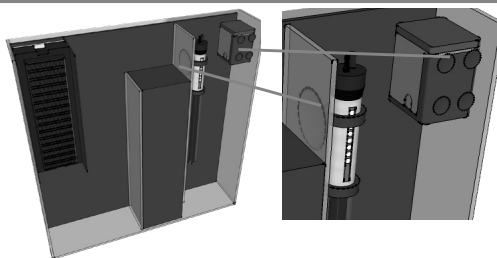
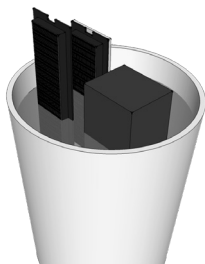

Using the provided suction cups mount the powerhead and heater to the wall of the aquarium inside of the filter compartment. Rinse ornaments* and place into the aquarium as desired.

ADD DECOR



Rinse aquarium gravel* well.

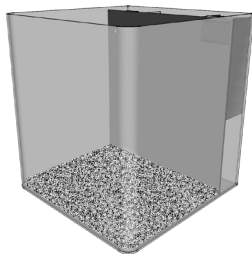

Gently pour the rinsed gravel into the aquarium.

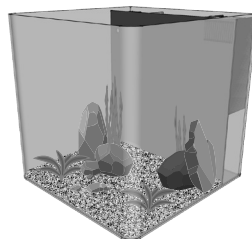

*sold separately



Ensure that all ornaments are securely placed so that they cannot fall over, which may harm aquarium inhabitants and damage the aquarium.

FILL AQUARIUM

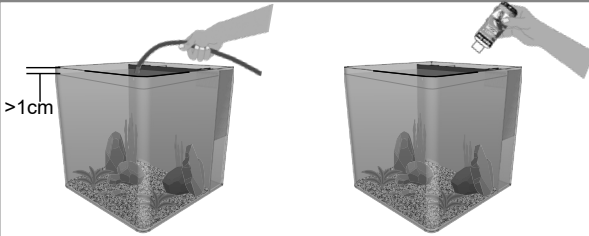

Fill the aquarium to no more than 1cm below the top.

Always treat the water with a water conditioner* to remove harmful chemicals.



Install the heater* near the filter as shown.

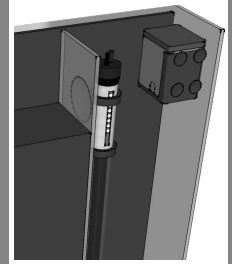

Do not plug the heater in unless it is fully submerged in water.

PLACE LID

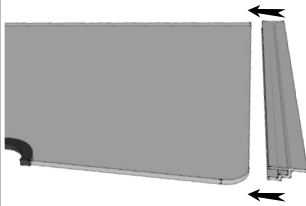

Place the lid supports by pushing them onto the glass lid.

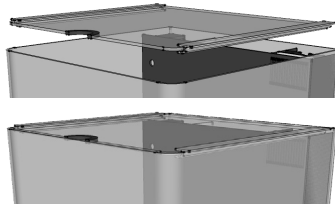

Place the lid on the tank.

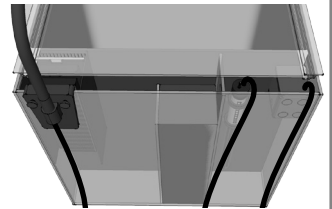

The lid should allow space at the back of the aquarium for the cables of the powerhead, heater and light fixture.

INSTALL LIGHT

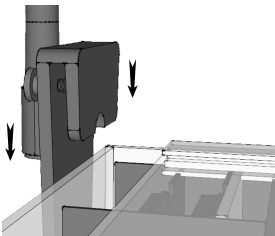

Attach the supports to the light unit and mount it on the aquarium as shown.

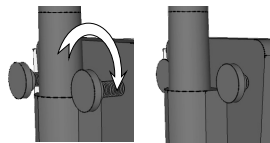

Tighten the screws enough to secure the light unit. Take care not to over tighten them.

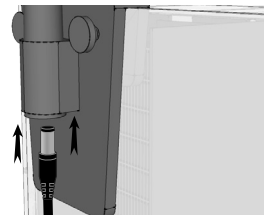

Make sure that your hands and all plugs are dry before connecting the power into the bottom of the light unit.

*sold separately



Ensure that your hands and all power cables are dry before plugging in equipment and turning power on.



MAINTENANCE

DAILY



Feed fish.

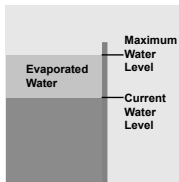

Check water level and top up if required.

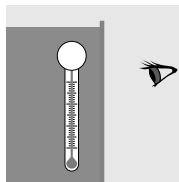

Check temperature and all equipment.

WEEKLY

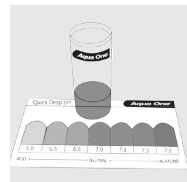

Test water parameters.

FORTNIGHTLY - 25% WATER CHANGE



Remove glass lid and light unit.

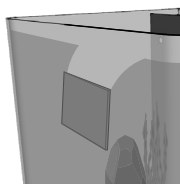

Use an algae scraper* and gently clean the glass.

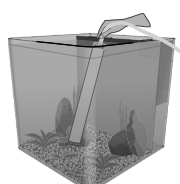

Use a Gravel Cleaner* to empty around 25% of the aquarium water into a bucket.



Remove and rinse the filter sponge and carbon cartridge in the old water from the aquarium.

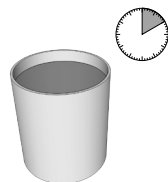

Fill the bucket with new water and treat it with water conditioner*. Allow to stand for 10 minutes.

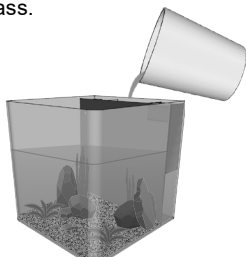

Gently refill the aquarium with the prepared water.



Replace all equipment on the aquarium. Check that your hands and power plugs are dry, and turn power back on.

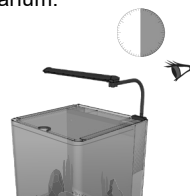

Check that all equipment is working correctly over the next half hour.

*sold separately



Never rinse the Sponge under the tap as you will kill the beneficial bacteria that live on the filter media and disrupt the balance of the tank.



Place the glass lid somewhere safe where it will not be broken while you are servicing the aquarium.



Replace the carbon cartridge every 6-8 weeks or sooner as required.

The fish and plants do not need to be removed when doing regular maintenance.

Place a towel on the floor in front of the aquarium in case of water spillage.



Unplug all equipment before beginning work on any part of the aquarium.

MONTHLY - FILTER MAINTENANCE

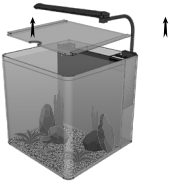

Remove light unit and glass lid.

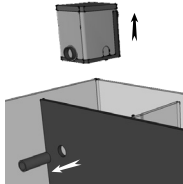

Disconnect outlet from the powerhead and lift out unit from filter compartment.

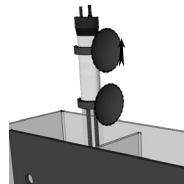

Remove heater from the filter compartment.

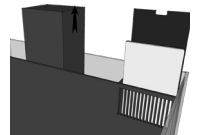

Remove sponge, ceramic and carbon cartridges.**

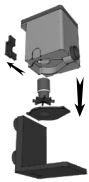

Remove powerhead casing, flow rate adjuster, impeller cover, and then the impeller.

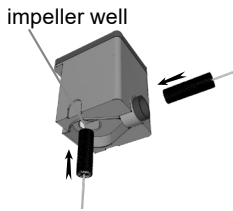

Use a pipe brush* to clean all pump components, paying particular attention to the impeller well.

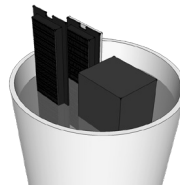

Remove some water from the aquarium and rinse the sponge and carbon cartridge.

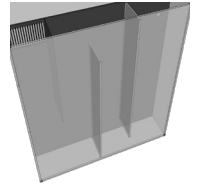

Rinse all other components of the filter to remove any debris or algae.



Replace all equipment on the aquarium. Check that your hands and power plugs are dry, and turn power back on.



Check that all equipment is working correctly over the next half hour.

*sold separately

**If the ceramic or carbon cartridge is due for replacement, discard it.



Take care not to lose small parts when servicing the aquarium, especially when cleaning filter components at a sink.



TROUBLESHOOTING



The external flexible cables of this unit cannot be replaced; if the cable is damaged, the part should be replaced.



If you are having a problem that you can't solve by following these steps, take the item to your Aqua One retailer for inspection as many issues may be resolved with a replacement part or an adjustment.

FILTER SLOW WATER FLOW

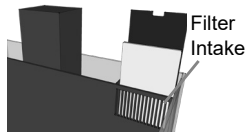

Check and clean intake strainer and filter intake.

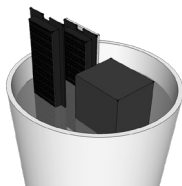

Media or pump are dirty. Clean filter and powerhead.

NO WATER FLOW

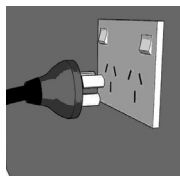

Check that power is available and connected properly.

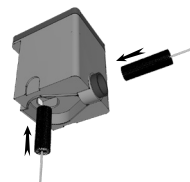

Pump is clogged. Clean powerhead.

LIGHT LIGHT WONT TURN ON

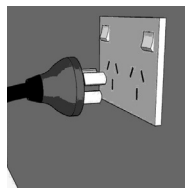

The individual LEDs in the light unit are not replaceable. If the LEDs in the unit fail, the whole light unit must be replaced.

Check that power is available and connected properly.

AQUARIUM AQUARIUM POSSIBLY LEAKING

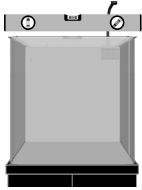

Check that aquarium is sitting level.

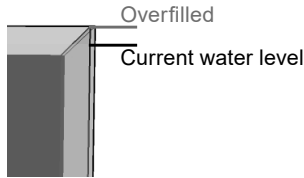

Make sure that the water level is not too high.



If an air stone is being used check it is not bubbling water over the rim

TESTING FOR LEAKS

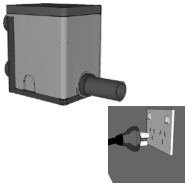

Turn off filter.

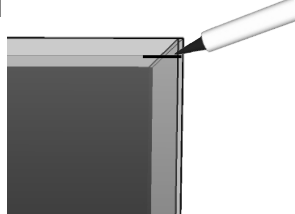

Mark water level.

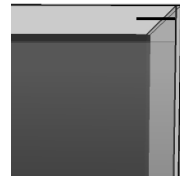

Wait an hour and check if water level has dropped.

IF WATER LEVEL DROPPED

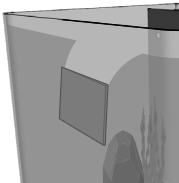

Empty and clean aquarium. Dry thoroughly.

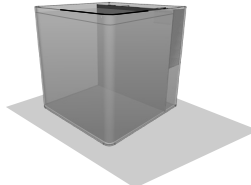

Place aquarium on a sheet of newspaper and fill carefully.

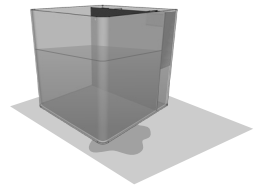

Leave for several hours and check paper for wet patches.



Aqua One®

Inspiring Excellence in Fish Care!

AQUA ONE 1 YEAR GUARANTEE



CUSTOMER CARE

Thank you for choosing this Aqua One product.

Your Aqua One product is covered for parts and labour for 1 year from the date of purchase as detailed in the terms of the Guarantee below. For any inquiries or concerns regarding this product or any of our products, please do not hesitate to contact your local Aqua One Retailer or visit Aqua One Customer Care online in your country of purchase via the websites listed.

Australia:
www.aquaone.com.au
New Zealand:
www.aquaone.co.nz
United Kingdom:
www.aquaone.co.uk
All other countries:
www.aquaone.com.au

Australian Consumer Law.

In Australia the Aqua One guarantee applies in addition to the guarantees that can not be excluded under the Australian Consumer Law. You are entitled to a replacement or refund for a major failure and for compensation for any other reasonably foreseeable loss or damage. You are also entitled to have the goods repaired or replaced if the goods fail to be of acceptable quality and the failure does not amount to a major failure.

About this Guarantee

The Manufacturer or Distributor, of Aqua One goods, is collectively known herein as "Aqua One". Please refer to contact details for Aqua One below or on the applicable Aqua One website. Any product that is covered by its own guarantee (as enclosed with the product) is subject to the conditions of that guarantee.

The benefits given to the purchaser, under guarantee, are in addition to all other statutory rights and remedies which the purchaser has in respect of products under legislation in the applicable country of purchase. This guarantee shall not affect any such rights and should be read subject to such legislation.

Terms and conditions of your Aqua One Guarantee

1. The Aqua One guarantee becomes effective from the date of purchase.
2. You must provide the proof of purchase before any repair or replacement of your Aqua one product is considered when requesting a guarantee claim.
3. All products subject to guarantee claim should be prepared for transportation in the original packaging or other comparable packaging which offers the same degree of protection.
4. Where products are repaired or replaced under guarantee, these products are guaranteed for the remainder of the original guarantee period, where permitted by local law. Where claims on inspection reveal goods are in normal working order, Aqua One will request reimbursement of all reasonable costs incurred.
6. Where Aqua One determines the products are being used in a manner contrary to the intended purpose/use, instructions, specifications or this guarantee, Aqua One reserves the right to terminate the guarantee and will provide written notice to the purchaser.

What is covered:

1. Aqua One warrants to the purchaser, for 1 Year from date of original purchase, to repair or replace products where fault is found due to defective materials or faulty workmanship and where goods do not operate in accordance with the instructions.
2. The guarantee covers any other products as enclosed with the product unless those products are provided with their own guarantee.
3. The guarantee covers the Aquarium against gluing breakdown resulting in leakage.

What is not covered

Where permitted by local law, the following exclusions and limitations apply in regard to the guarantee:

1. Glass or Acrylic scratching, for whatever reason caused after purchase.
2. Glass breakage for whatever reason after purchase unless it is established that the breakage was caused prior to purchase.
3. The LED light units used in this aquarium are designed to last up to 5 times longer than conventional light tubes. All LED lights are made up of multiple LEDs and occasionally individual LEDs can break down as with all LED devices. The effectiveness of your LED light unit will not degrade as quickly as conventional light tube output would over a period of 6-12 months. We would replace a unit subject to the terms of the guarantee if more than 20% of the individual LED's have failed.
4. Product guarantee claims where fault is due to, but not limited by a) misuse b) neglect c) abuse d) fire or flood e) normal wear and tear f) accidental breakage g) Acts of God h) mains voltage fluctuation or supply problems i) connection to any voltage other than what is stated on the rating plate j) modification or tampering to electrical cord or plug, k) vermin, insects or foreign objects l) liquid spillage or submersion of goods not designed to sustain such use or duress.
5. Where inspections reveal the products are in normal working order including where noise or vibration is consistent with normal product operation.
6. Attempted repairs or modifications by unauthorised persons, including but not limited to the drilling of holes in the aquarium glass by unauthorised persons.
7. Where the product's factory rating plate has been removed, altered, damaged or is rendered illegible.
8. Where products are not installed, operated or maintained in accordance with Aqua One's product instructions, specifications or this guarantee.
9. Replacement or repair of worn consumables such as: suction cups, filter media/cartridges, impellers and shafts, light tubes, lamps, bulbs and starters.
10. Replacement of lost products, parts or components.
11. Costs associated with products transportation, removal, installation, postage or cost of insurance.
12. Any damage incurred whilst installing, transporting or moving the goods.
13. Subject to certain local statutory rights and obligations to the contrary, and this guarantee shall not affect those rights or obligations, where, to the full extent permitted by law: 1. all express and implied warranties and conditions under statute or general law, are expressly excluded and Aqua One, where permitted, will limit liability as follows and at Aqua One's option to: in regard to products either a) the replacement of goods or supply of equivalent goods b) the repair of products or the cost of replacing the products OR of acquiring equivalent products OR in regard to services either c) the re-supply of services d) the cost to re-supply services. 2. Aqua One will not be liable for any loss or damage, including consequential loss or damage either directly or indirectly, or for any incidental expenses, of any kind, and in any way whatsoever.

Aqua One may be contacted in:

Australia
Kong's (Aust.) Pty. Limited
PO Box 863, Ingleburn
1890 NSW Australia
www.aquaone.com.au

Hong Kong
Kong's Aquarium Supplies Co., Ltd
No 31, 3/F Thriving Industrial Centre
26-38 Sha Tsui Road, Tsuen Wan,
Hong Kong
www.aquaone.co.hk

New Zealand
Kong's (NZ) Limited
PO Box 15 - 183, Tauranga
3015 New Zealand
www.aquaone.co.nz

United Kingdom
Kong's (UK) Limited,
C/O Aqua Pacific UK Ltd.
PO Box 268
Romsey Hampshire, SO51 0WW
United Kingdom
www.aquaone.co.uk